

Installation Drawing for EWT Series – *Single circuit, Normally Open*

Models:

CR 135 EWT, CF 135 EWT, CR 165 EWT, CF 165 EWT, CR 200 EWT,
 CF 200 EWT, CF 285 EWT

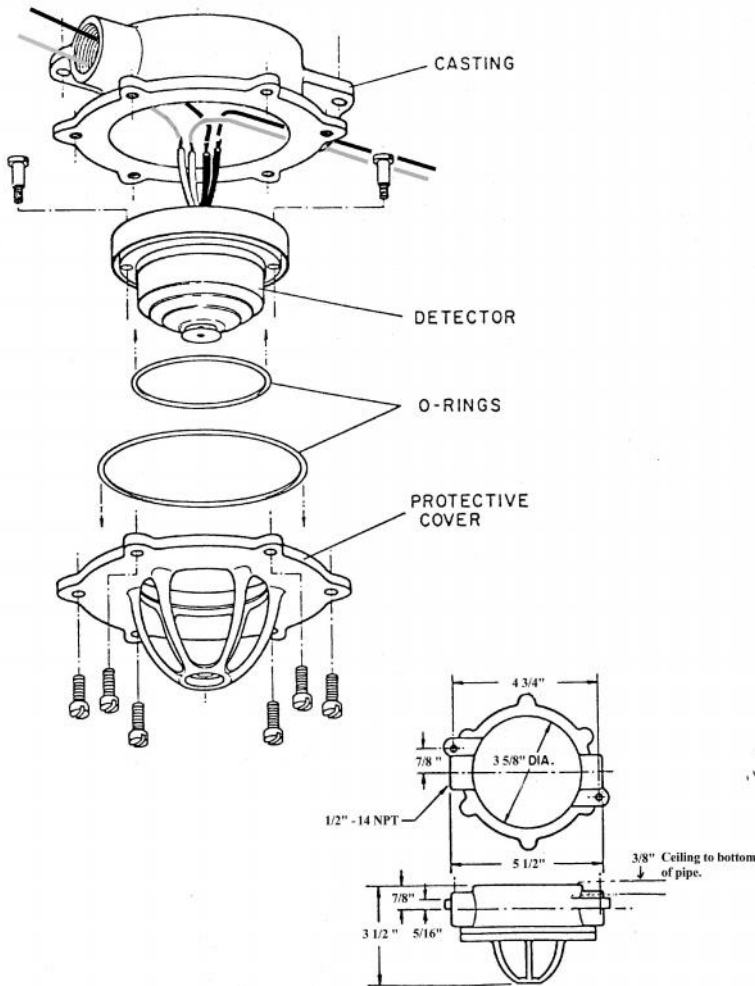

Installation Notes

- 1) A **pair** of wires (fly leads) of the same colour, black or white, is connected to *one side* of the Normally Open contacts within the detector.
- 2) Spacing between detectors on a flat, smooth ceiling up to 3m in height is:
 - 50ft (15.2m) for CR-type units
 - 30ft (9.1m) for CF-type units
 - Distance from any wall is 25ft (7.5m) and 15ft (4.5m) respectively
- 3) Only CR-type units (combination rate-of-rise and fixed temperature) may be tested with a controlled heat source such as a hair dryer.
- 4) CF-type units (Fixed Temperature Only) cannot be tested.

